

CRANE BASE

You could say that the crane is the model for all other origami figures, since folding it involves so many of the basic techniques. Follow the arrows and fold the figure, remembering to make each fold and crease neat and exact.

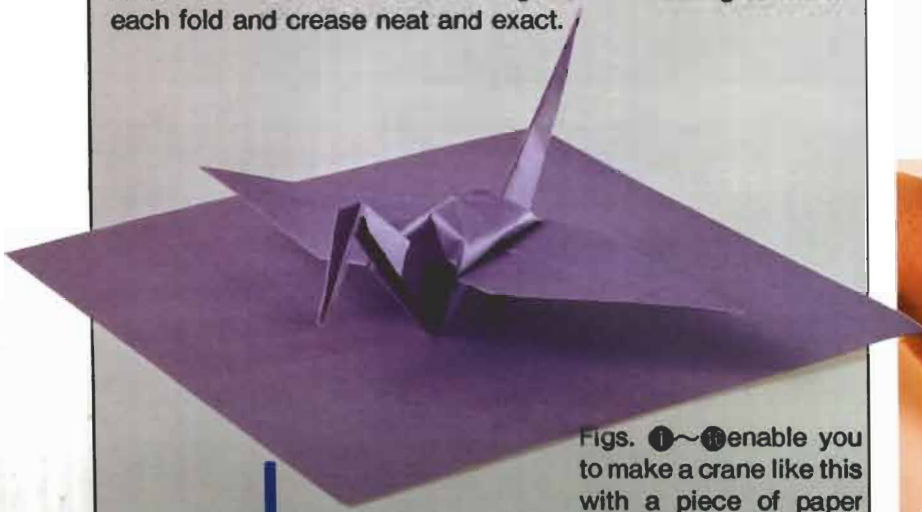

Figs. ①~⑤ enable you to make a crane like this with a piece of paper the size of the one below.

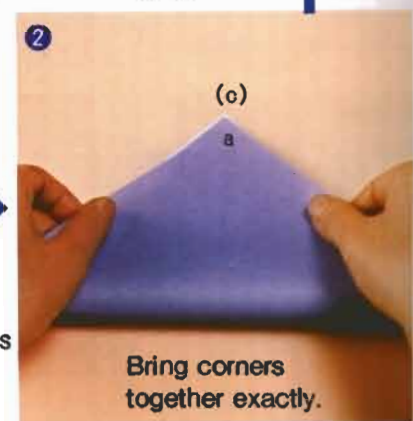
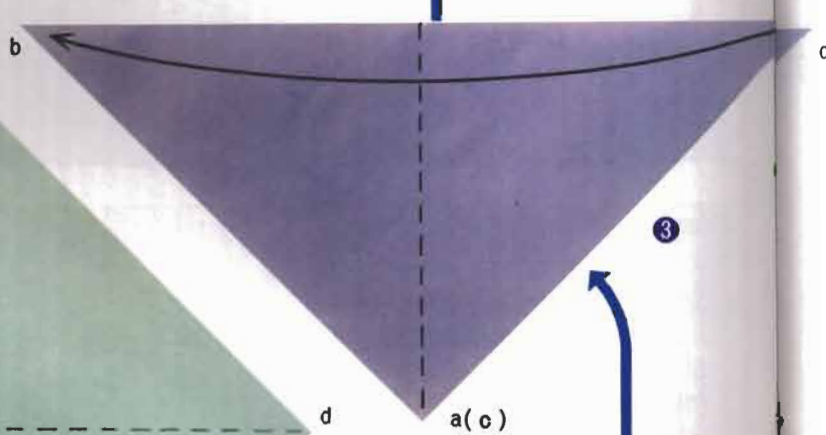
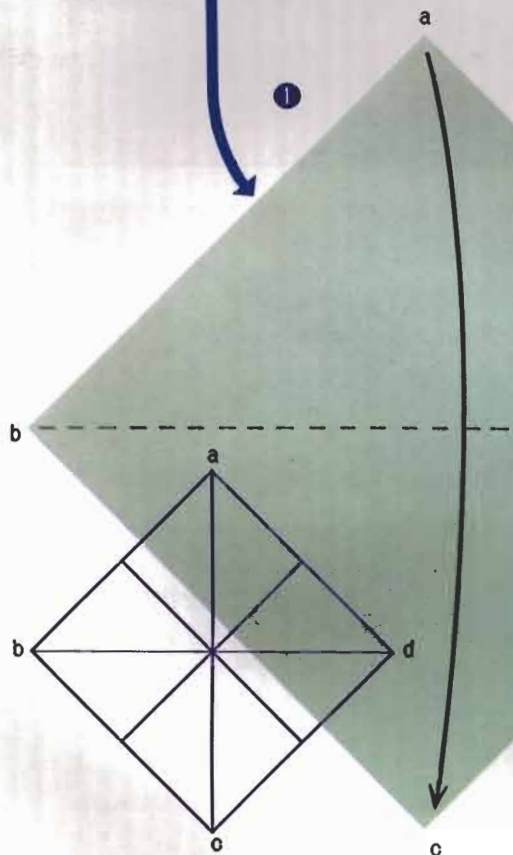

←Figure on the left shows you the creases you will have after reaching picture ②.

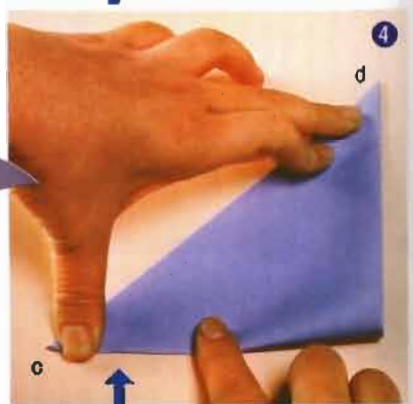
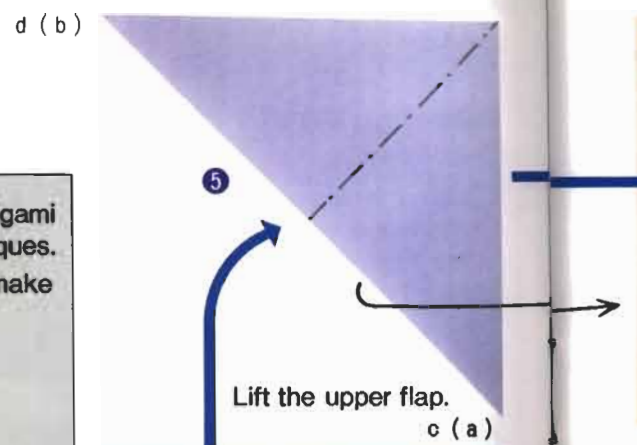

d (b)

c (a)

a (c)

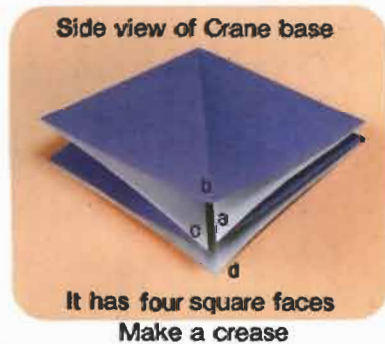
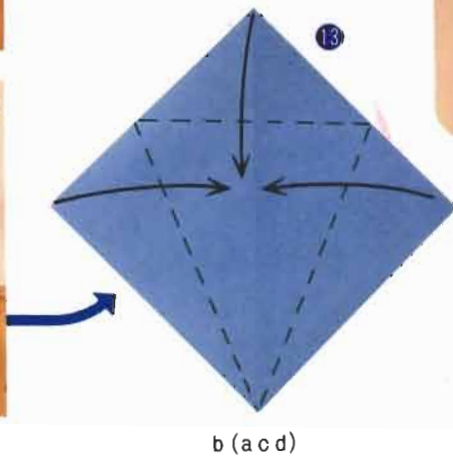
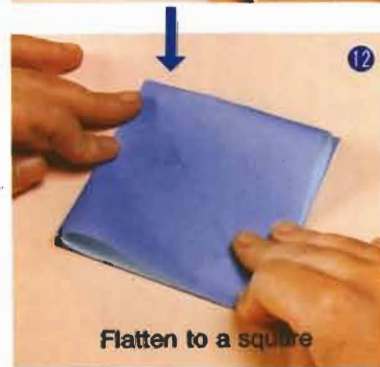
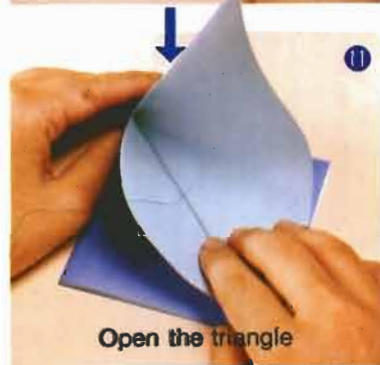
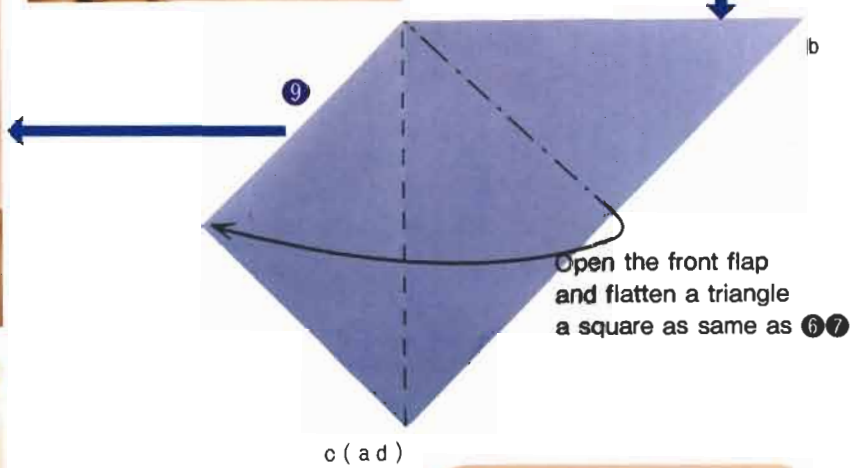
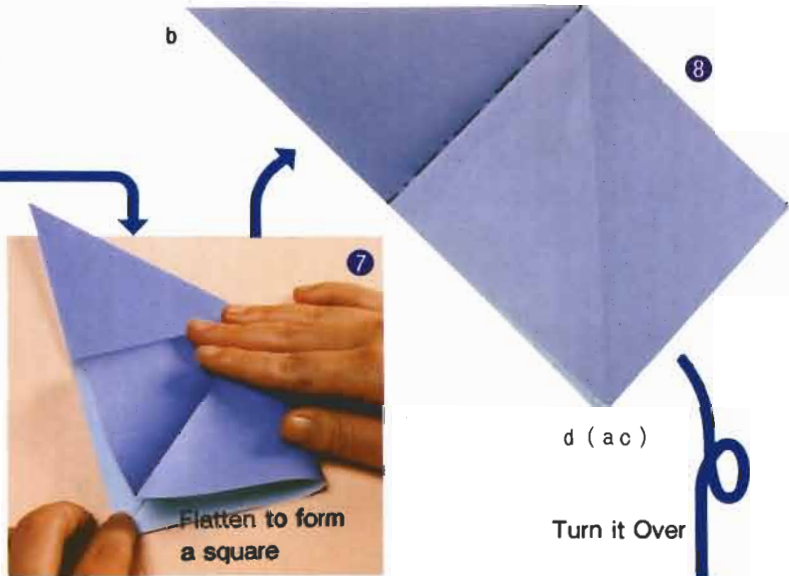
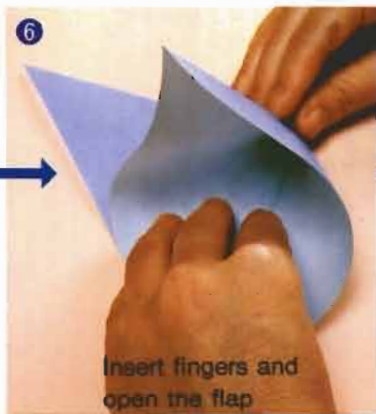

Star-Shaped Box

Morning-glory

Flapping Crane

Nesting Crane

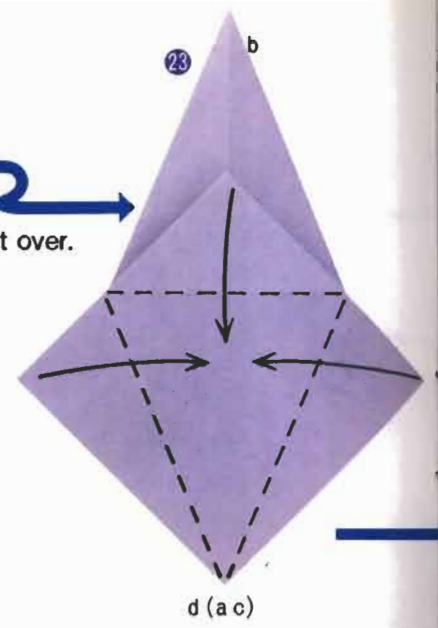
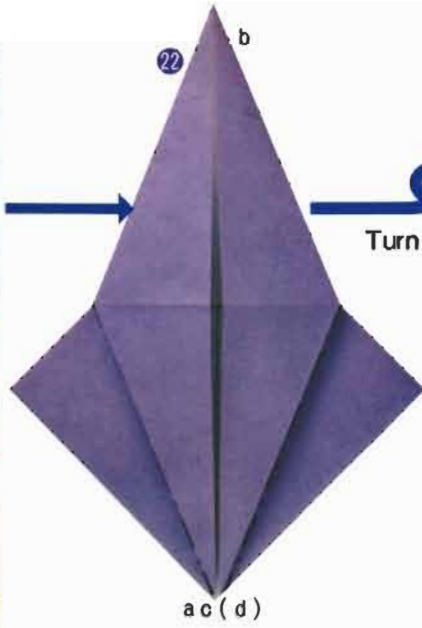
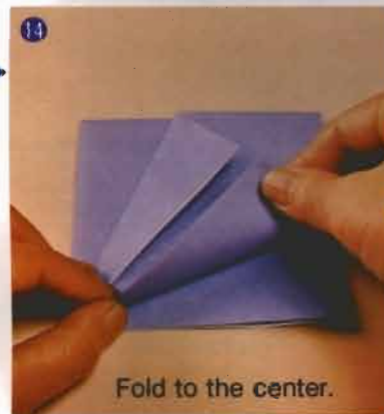
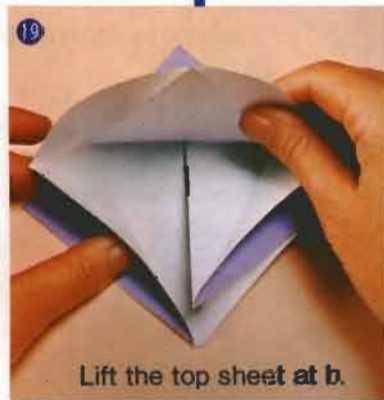
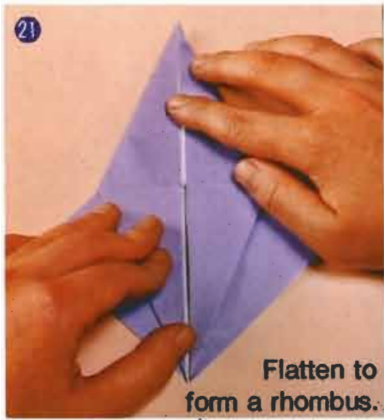

Turn it over.

Make the same creases on the other side.

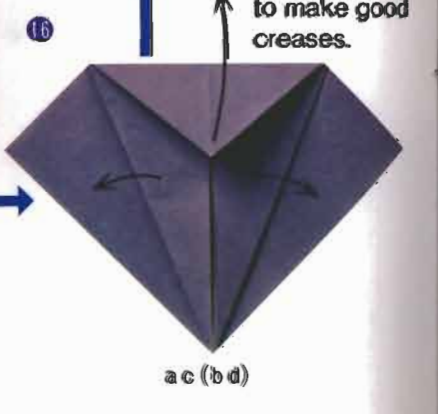
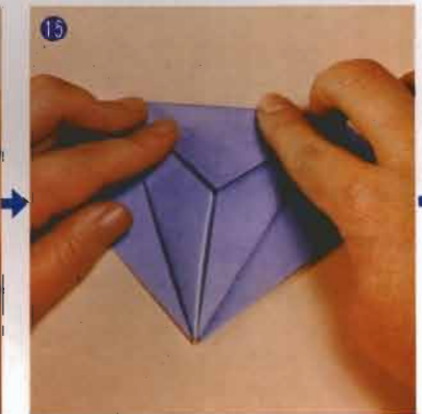
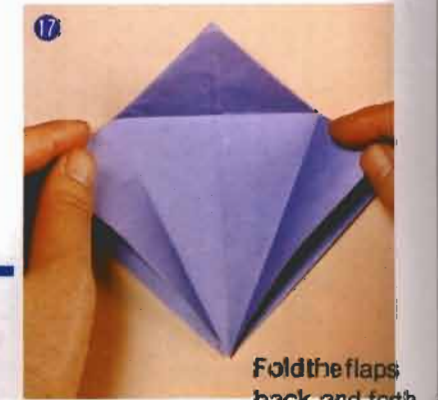
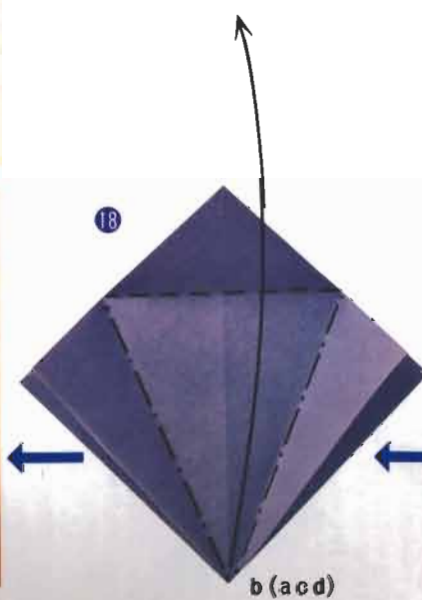

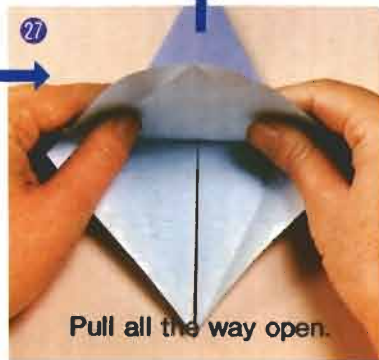
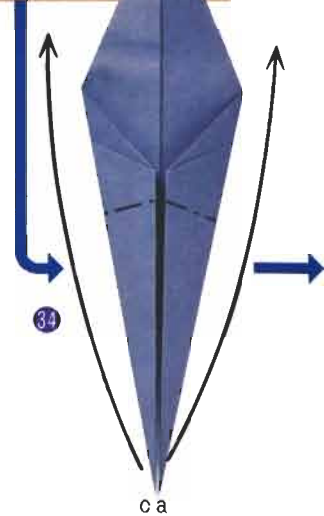
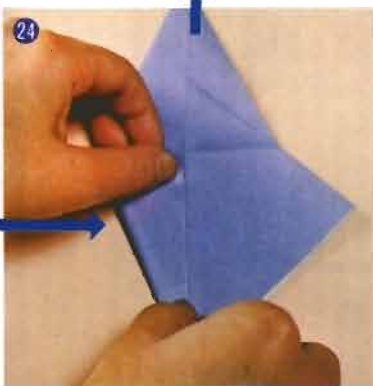
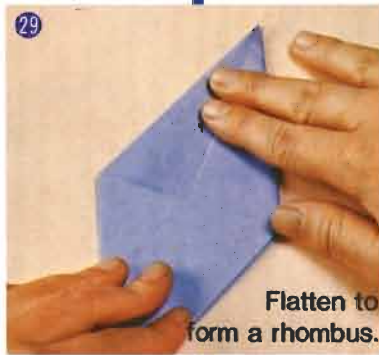
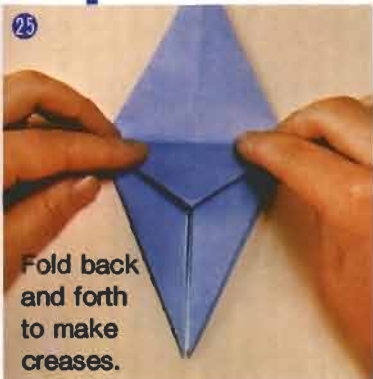
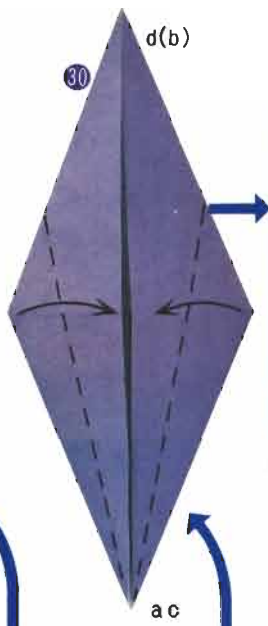
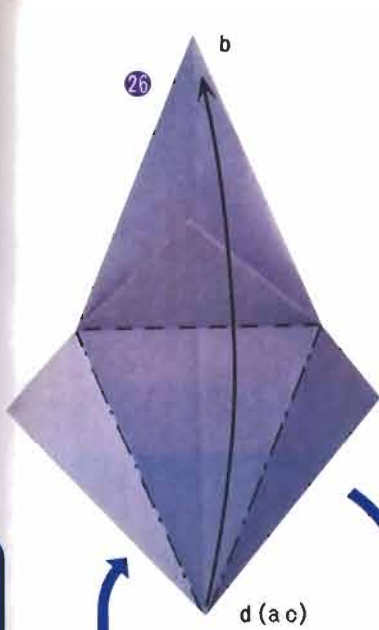

Turn it over.

Creasing as directed in Figs. 16 and 25 gives you flexible base line creases that will make folding the figure easy when, for example, later you have to turn a valley fold into a mountain fold.

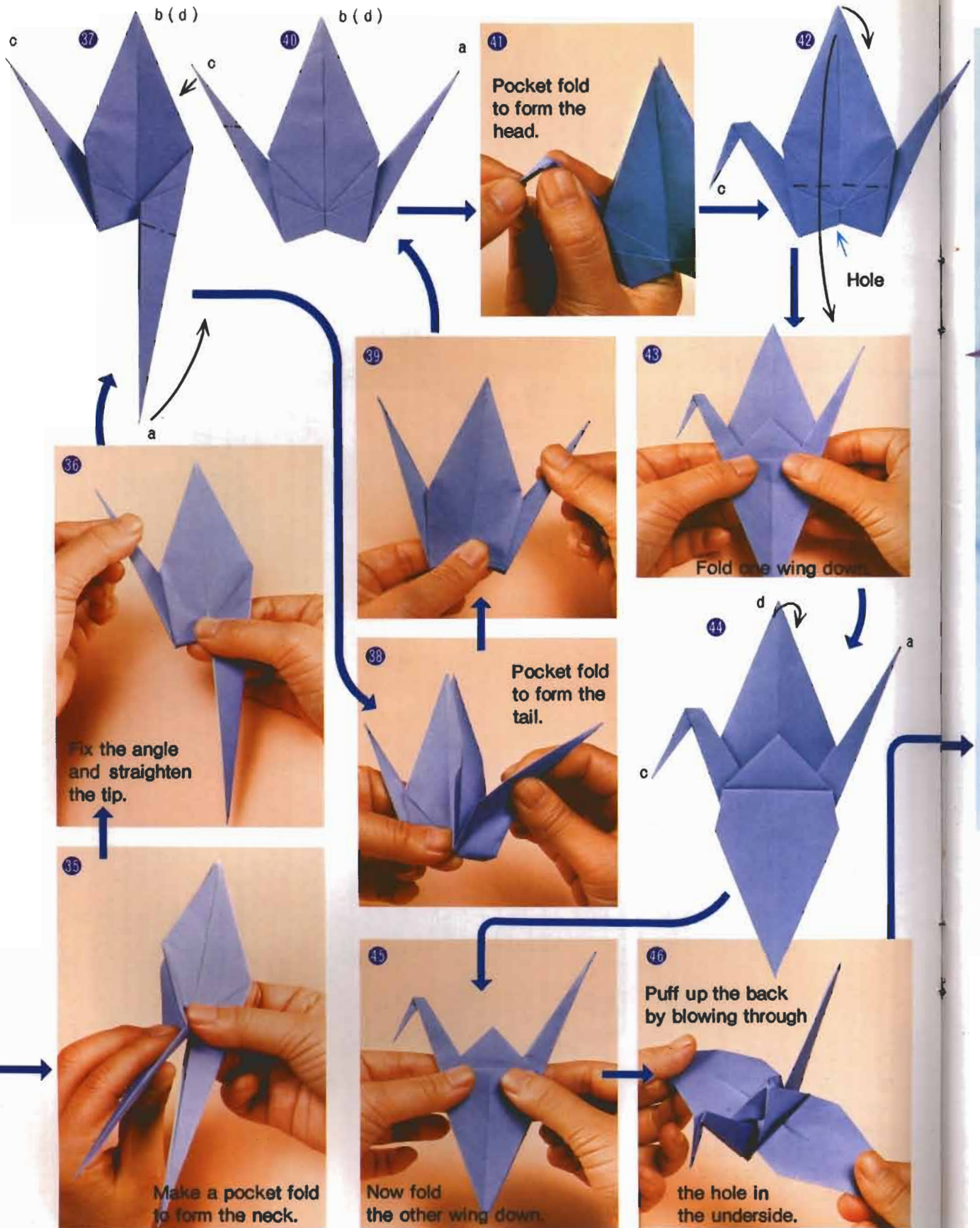

Crane

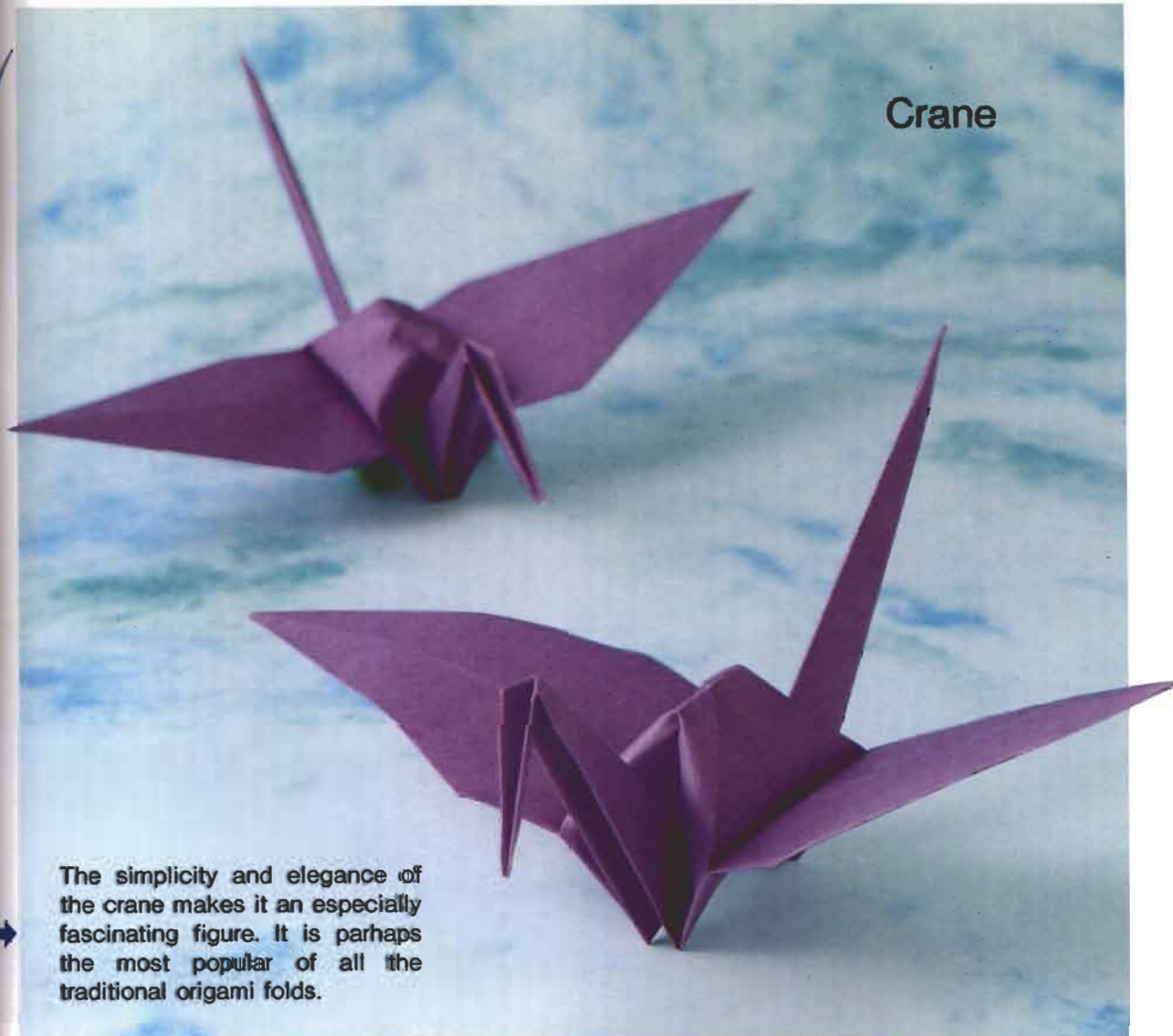

The simplicity and elegance of the crane makes it an especially fascinating figure. It is perhaps the most popular of all the traditional origami folds.

Begin with a

Crane Base

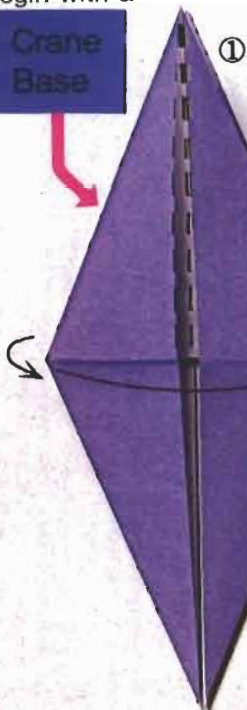

①

Follow steps ①~③⑩ of the Crane Base to set this form.

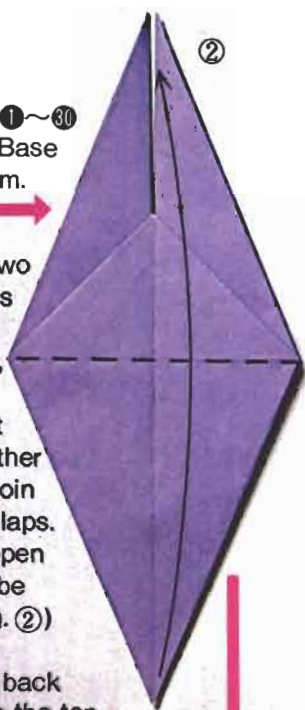

②

With the two open tips at the bottom, bring the front flaps together and then join the back flaps. Now the open tips will be on top. (Fig. ②)

Fold front and back bottom flaps to the top.

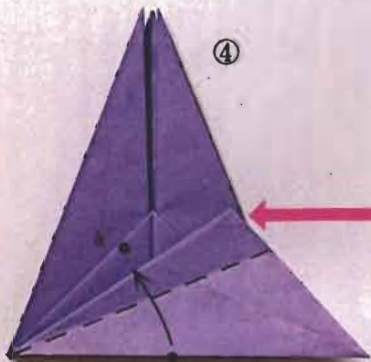

③

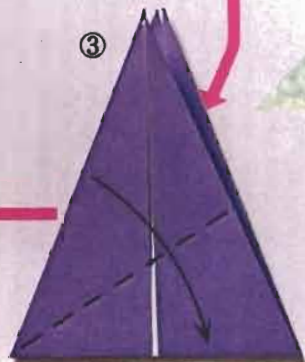

④



⑤

Fold the upper flap down and join a with a.

Join b with b.

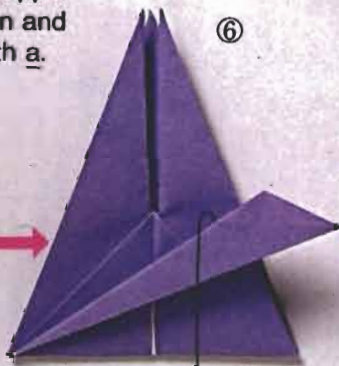

⑥

Now fold the whole wing down.

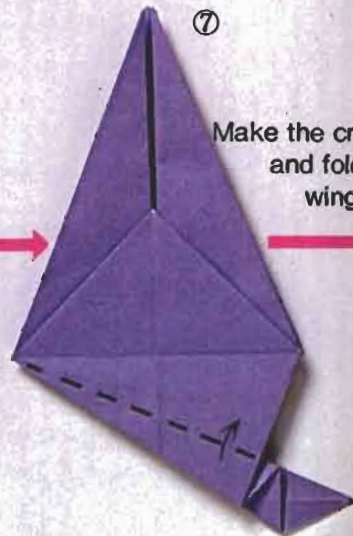

⑦

Make the crease and fold the wing up.



Nesting Crane

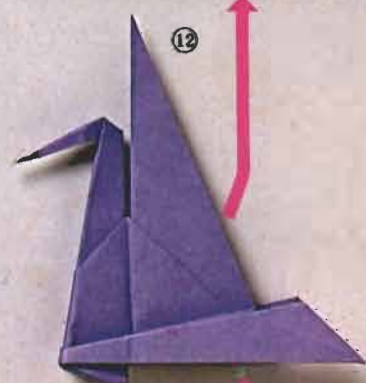
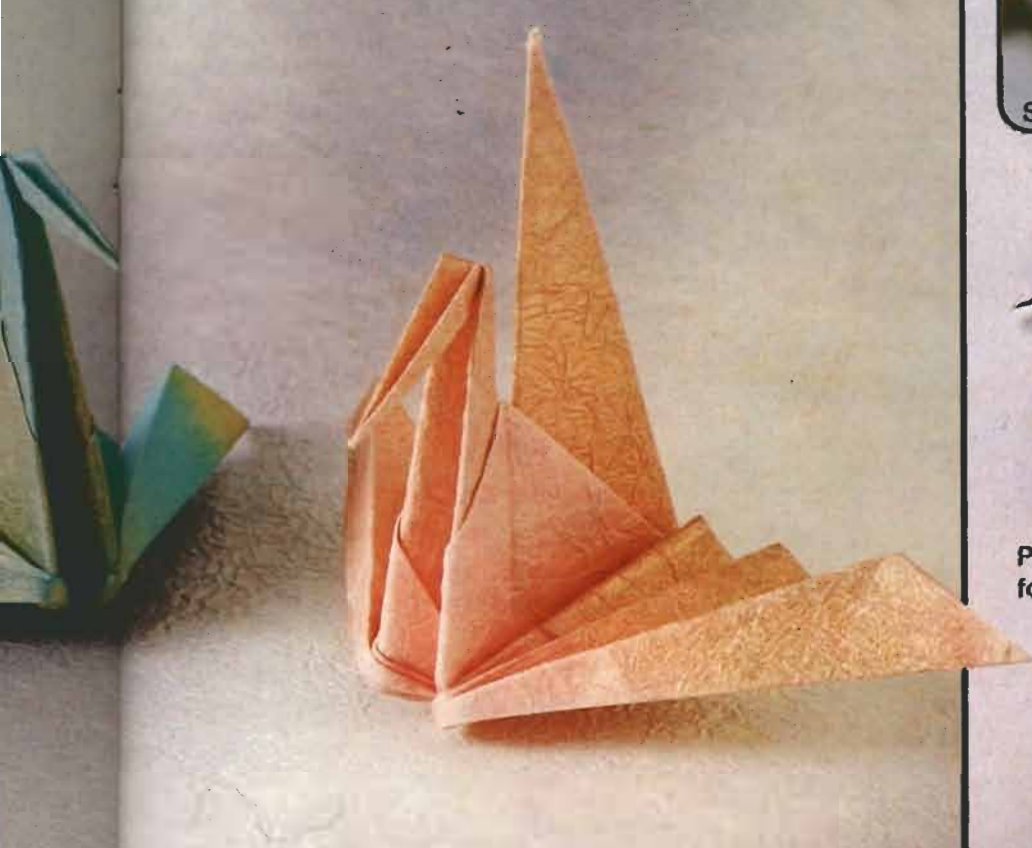

Pocket fold to form the head.



Make the crease and fold front and back flaps inside.

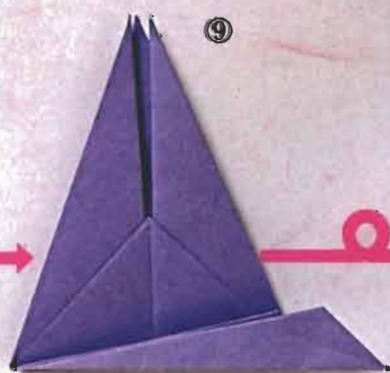
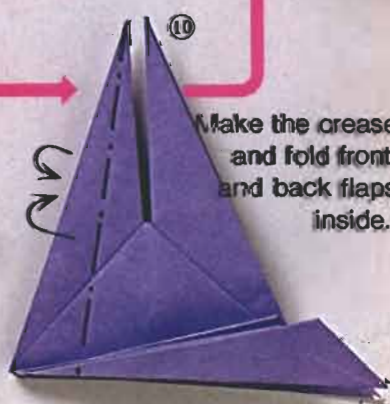

Now follow these same steps ③~⑧ to fold the other wing.

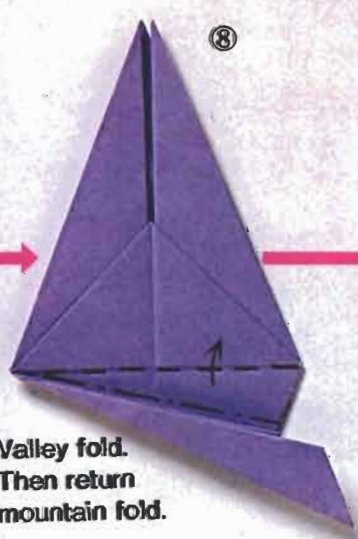

Valley fold. Then return mountain fold.

the crease fold the wing up.